



EFFECTIVE DEWATERING

– when and where you need it

GRUNDFOS DWK RANGE, 50 HZ

If you're a contractor working with building or infrastructure construction, the DWK range offers quality pump solutions that remove all rainwater and ground water from your construction area.

DURABLE AND COMPACT DEWATERING PUMPS

– designed for simplicity and use

The DWK range of submersible contractor pumps from Grundfos combines durable performance with ease of installation, providing an immediate return on your dewatering solution investment.

The solid cast iron construction and narrow design means the DWK range is ideal for pits, for temporary or fixed installation, in fact any situation where effective dewatering is needed.

If high-pressure pump performance unhindered by sand or other abrasives is required, or if the available power supply is limited, the DWK range provides the effective dewatering solution for you.

APPLICATION

- Underground drainage pit
- Storm water transit
- Flood Control
- Seepage water
- Surface water with small solids



be think innovate

DWK PUMP FEATURES – and what they offer you

HOSE, STORZ OR FLANGE CONNECTION ON THE TOP

Top-discharge with different connection types available for multiple use of the pump, depending on conditions and specific needs.

HIGH EFFICIENCY MOTOR

The long-life motor used in the DWK range keeps operating costs down and maintains even performance.

INTEGRATED THERMAL PROTECTION

The integrated circuit-cut protects the motor from overheating and operates independently, removing the need for constant monitoring.

EASY MAINTENANCE OIL PLUG

The ability to inspect oil condition in the seal chamber makes it easy for you to plan maintenance and service your pump.

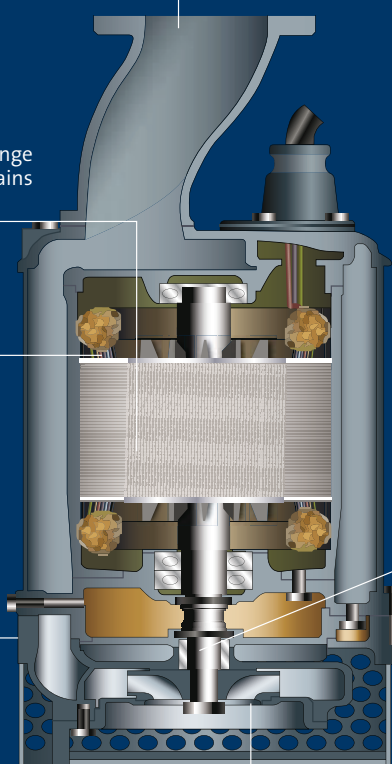

SHAFT SEAL

The triple-system sealing provides longer operation and less downtime, and consists of a double mechanical seal with an easily replaceable lip seal.

HIGHLY EFFICIENT AND WEAR-RESISTANT IMPELLER

The stainless steel high-chrome impeller maintains its performance, ensuring an increased lifetime.

PERFORMANCE OVERVIEW

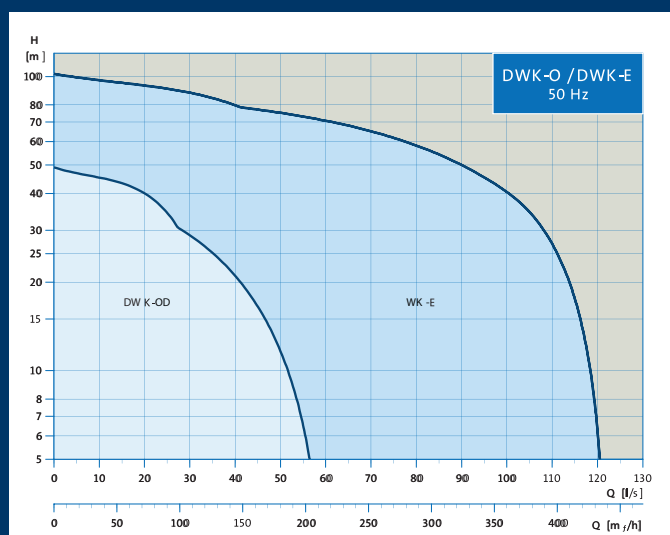

For more information contact us:

in.grundfos.com

1800-102-2535 (One Office Toll-free), 1800-345-4555 (Toll-free)

oneoffice.india@sales.grundfos.com, salesindia@grundfos.com,
serviceindia@grundfos.com

GRUNDFOS 